

KIT TO ADD LOCK TO OPEN PAPER DOOR

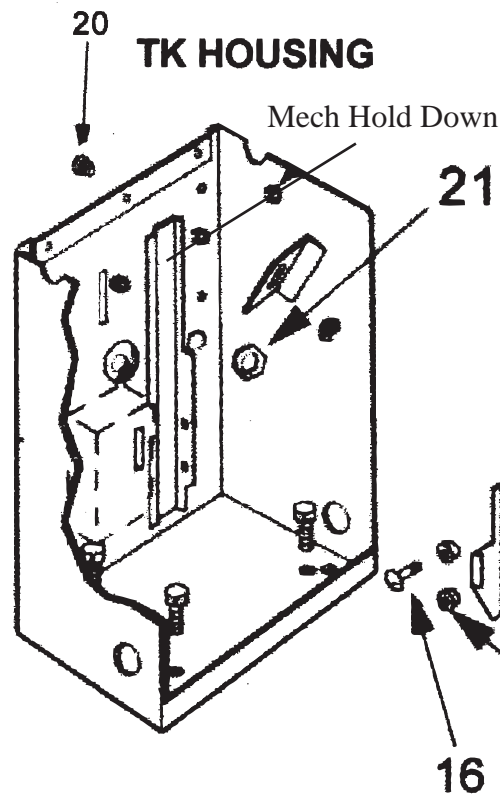

- 15. Lift bracket
- 16. 8-32 x 3/8 screw
- 17. Bushing
- 18. 8-32 kep nut
- 19. Lift bracket rod & cam
- 20. Lock
- 21. Nut for mount lock
- 22. Lock washer
- 23. 10-32x 3/16 screw

1. Remove TK Mech
2. Remove lock hole knock-out, located 2 1/2 inches to left of push button on outside of housing. From outside of housing strike bottom half of lock hole knock-out using large screwdriver and hammer (Hit it hard)
3. Install one-way national lock with key teeth toward push button
4. Install lift bracket on mech holddown with two larger 1/4" x 1" slots facing up.
 - a. place bushing on 8-32 x 3/8" screw with small shoulder away from screw head
 - b. place screw with bushing though top 1/4" x 1" slot on the lift bracket and then through top 1/8 hole in holddown and put nut on it, repeat same for lower hole
5. Tighten nuts securely
6. Make sure lift bracket moves up and down freely, adjust with pliers if necessary (bracket must float absolutely free)
7. Feed lift bracket rod through 1/8 x 5/8 slot in bottom of lift bracket from side of housing to inside of housing
8. Move lock into position with key horizontally.
9. Place lift rod cam on lock with cam straight up and secure with lock washer and 10-32 x 3/16" screw
10. Turn key clockwise, lift rod should raise bracket up freely and bracket should fall freely on its own
11. Reinstall TK Mech
12. Turn key and make sure lift bracket catches and raised T-825 door latch, also make sure bracket falls back down freely